

MD-3



Functional Considerations

The Light Viper MD-3 is very simple device designed to translate RS-232, RS-422 and MIDI data into TTL control data, thereby allowing it to be transported via fiber through the “control circuit” connectors that appear on the LightViper VIS-1832, VIS-4832, VIM-1832, VIM-1032, VIM-1808 and VIM-0808. The MD-3 is designed to be used in pairs. A single MD-3 contains (1) RS-232 connector, (1) RS-422 connector, and (1) MIDI connector located on the front of the MD-3. On the back of the unit there are (3) corresponding RJ-45 connectors, and a switch to determine MIDI send/receive status.

Standard Components

In its standard configuration, the Light Viper MD-3 data translation and transport system consists of three primary components:

- 2 ea. Of the MD-3 - This is the hardware interface. One unit is placed on each end of the data connection.
- RS-422, 232 or MIDI input / output cables – These cables connect the devices transmitting the control signals into the MD-3 on the “send” side of the data path, as well as connecting the data output from the MD-3 to the devices on the receiving end of the data path.
- CAT-5 jumpers – one CAT-5 jumper cable at each end is required for each of the data protocols being translated (RS-422, RS-232 or MIDI). These connect the RJ-45 connectors on the MD-3’s to the LightViper “Control Circuits” connectors on both the send and receive end of the data path.

Getting Started

Setting up and using your Light Viper MD-3’s is quick and simple. Just follow these steps:

1. Mount (1) MD-3 close to the VIM-1832, VIM-1032 or VIM-1808 (“send” or mixer end)
2. Mount (1) MD-3 close to the VIS-1832, VIS-4832 or VIM-0808 (“receive” or stage end).
3. Connect the MD-3’s using standard DB9 (RS-422 or RS-232) control cables, or MIDI control cables, on both send and receive ends of the data path.
4. Connect the MD-3’s to the LightViper “Control Circuit” RJ-45 connector on both ends of the data path using CAT-5 jumper cables.
5. If using MIDI control, set the MIDI switch on the data origination end to “send”, and set the MIDI switch on the data receive end to “receive”.

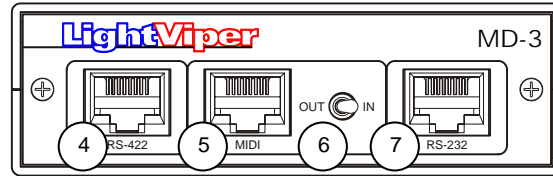
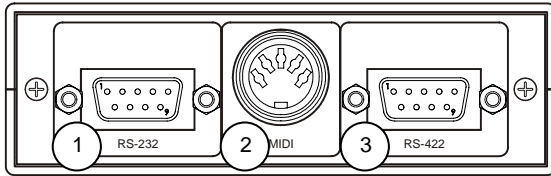

MD-3 Front Panel

- ① RS-232 connector – This connector is used to input RS-232 control data at the “send” origination end, and / output RS-232 control on the “receive” or destination end.
- ② MIDI Connector – This connector is used to input MIDI control data at the “send” origination end, and output MIDI control data at the “receive” or destination end.
- ③ RS-422 connector – This connector is used to input RS-422 control data at the “Send” origination end and output RS-422 control data at the “receive” or destination end.

MD-3 Rear Panel

- ④ RJ45 connector #1 – Connects the RS-422 output data to the MD-3 of the LightViper “control circuit” connector on the “send” side of the chain, and connects the output of the “control circuits” connector to the MD-3 on the “receive” side of the chain.
- ⑤ RJ-45 connector #2 – Connects the MIDI output data to the MD-3 of the LightViper “control circuit” connector on the “send” side of the chain, and connects the output of the “control Circuits” connector to the MD-3 on the “receive” side of the chain.
- ⑥ MIDI Send / Receive switch - This switch must be set to the appropriate “send” or “receive” setting as MIDI requires this setting to correctly send / receive MIDI data.
- ⑦ RJ-45 connector #3 – Connects the RS-232 output data to the MD-3 of the LightViper “control circuit” connector on the “send” side of the chain, and connects the output of the “control circuits” connector to the MD-3 on the “receive” side of the chain.

MD-3 Pin Out Diagram

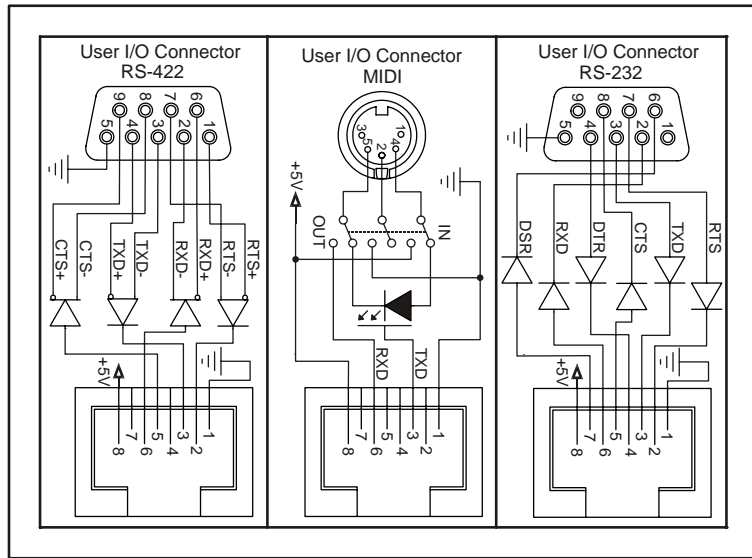

LightViper Specifications

- Translates up to 3 control protocols simultaneously
- Powered from LightViper device via RJ-45 connector(s)
- Heavy gauge steel construction

1. General Specifications

Operating Temp	0 to +50°C ambient temperature.			
Switches	-	MIDI send/receive	-	
Input Connections	RS422 - DB9	MIDI - 5 pin MIDI	RS232 - DB9	
Output Connections	RJ-45	RJ-45	RJ-45	
DC Power	5	5	5	VDC
DC Current	60	60	60	mA
Dimensions	3" L X 4" W X 1" H			
Weight	1 lb. each			

2.1 Data Characteristics

Data Rate	RS-422	50kb / sec
	MIDI	32kb / sec
	RS-232	50kb / sec

